

Copyright © 2012 by Big Bike Parts, Inc. No part of this instruction sheet may be reproduced without the written permission of Big Bike Parts, Inc.

PART NO.
52-810 / 52-811

HEADLIGHT END TRIM CHROME
LED HEADLIGHT END TRIM CHROME
HONDA GL1800 GOLDWING 2001-2012

8/20/2012

| | | | | |
|---------------|----------------------|--|--------------------|------------------|
| TOOLS NEEDED: | PHILLIPS SCREWDRIVER | 8MM SOCKET WRENCH WIRE CRIMPERS (52-811 ONLY) | 10MM SOCKET WRENCH | 5MM ALLEN WRENCH |
|---------------|----------------------|--|--------------------|------------------|

| | | |
|----------------------|---------------------------------|-----------------------------|
| COMPONENTS INCLUDED: | 52-811: (2) T-TAP CONNECTORS | (2) MALE PUSH ON CONNECTORS |
|----------------------|---------------------------------|-----------------------------|

PLEASE READ THROUGH AND UNDERSTAND THESE INSTRUCTIONS BEFORE BEGINNING. IT MAY BE A GOOD IDEA TO LABEL SCREWS AND PARTS AS THEY ARE REMOVED FROM THE BIKE SO YOU KNOW WHERE THEY GO WHEN REINSTALLING EVERYTHING.



52-810
Video



52-811
Video

INSTALLATION:

1. PLACE MOTORCYCLE ON CENTER STAND.
2. RELEASE WINDSHIELD CLAMP LEVERS ON BOTH SIDES.
3. RELEASE RUBBER BOOTS AROUND BOTH MIRRORS AND PIVOT THE MIRRORS FORWARD.
4. REMOVE THE BLACK WINDSHIELD CLAMP BY REMOVING THE TWO NUTS WITH A 10MM WRENCH ON EACH SIDE AND THE BOLT IN THE FRONT CENTER UNDER THE PLASTIC FLAP.
5. USING A PHILLIPS SCREWDRIVER REMOVE THE SCREWS ATTACHING THE WINDSHIELD AND SET THE WINDSHIELD ASIDE.
6. USING A 10MM WRENCH REMOVE THE TWO BOLTS AND WASHERS BEHIND EACH OF THE MIRRORS HOLDING THE WINDSHIELD GARNISH IN PLACE. THEN REMOVE THE GARNISH BY PULLING IT FORWARD TO RELEASE IT FROM THE RUBBER GROMMETS IN THE FRONT CENTER. (SEE FIG.1)
7. USING A 5MM ALLEN WRENCH AND A PHILLIPS SCREWDRIVER REMOVE THE SCREWS SHOWN IN FIG. 2 FROM THE FRONT OF THE DASHBOARD. ALSO REMOVE THE TWO PLASTIC RIVETS IN THE CENTER. (SEE FIG. 2)
8. USING AN 8MM WRENCH AND A PHILLIPS SCREWDRIVER REMOVE THE FAIRING NOSE TRIM. THERE ARE TWO PHILLIPS SCREWS ON THE BOTTOM SIDE AND ONE BOLT ON THE FRONT. (SEE FIG. 2)
9. REMOVE THE THREE PIECE INNER FRONT COWL FROM THE AREA BEHIND THE FRONT WHEEL OF THE BIKE. THERE ARE TWO ALLEN SCREWS ON THE TOP OF THE LOWER COWL AND SEVERAL PLASTIC RIVETS THAT FASTEN THE INNER COWL. REMOVE THE CENTER PIECE FIRST. (SEE FIG. 3)
10. REMOVE THE FAIRING TRIM FROM BOTH SIDES OF THE FAIRING. CAREFULLY PRY FROM UNDER EACH FAIRING TRIM BEING CAREFUL NOT TO SCRATCH THE PAINT OR DAMAGE THE FAIRING TRIM. (SEE FIG. 4)
11. USING A 5 MM WRENCH REMOVE THE BUTTON HEAD SCREWS HOLDING THE BACK OF THE FAIRING TO THE BIKE. USING A 10MM WRENCH REMOVE THE BOLTS ON EACH SIDE OF THE FAIRING NEXT TO THE MIRRORS. ALSO REMOVE THE WASHERS. (SEE FIG. 5)
12. PUT A TOWEL OR A RAG ON THE TOP OF THE FRONT FENDER TO PROTECT IT FROM DAMAGE. NOW CAREFULLY PULL THE FAIRING FORWARD UNTIL THE WIRING HARNESSSES FOR THE HEADLIGHTS COME TIGHT.
13. UNPLUG ALL OF THE WIRING HARNESSSES ATTACHED TO THE FAIRING. TAKE NOTE TO WHICH ONE CAME OFF FROM WHICH LIGHT.
14. REMOVE FAIRING FROM BIKE AND LAY IT ON A TOWEL OR A CARPET.
15. USING A 10MM WRENCH REMOVE THE FOUR BOLTS HOLDING EACH HEADLIGHT ASSEMBLY TO THE FAIRING AND REMOVE THE HEADLIGHT ASSEMBLIES. (SEE FIG. 6)
16. USING A PHILLIPS SCREWDRIVER REMOVE THE THREE SCREWS HOLDING EACH OF THE OEM HEADLIGHT END TRIMS TO THE FAIRING.
17. REMOVE THE CLIPS FROM THE OEM END TRIMS AND ATTACH THEM TO THE NEW SHOW CHROME END TRIMS.
18. INSTALL BOTH NEW END TRIMS INTO THE FAIRING.
19. IF INSTALLING 52-811 (WITH LED LIGHTS) CONNECT THE TWO BLUE WIRES TOGETHER AND THE TWO BLACK WIRES TOGETHER AND CRIMP THE MALE PUSH-ON CONNECTORS TO THE ENDS OF EACH SET OF WIRES. IF NOT SKIP TO STEP 21.
20. USING THE TWO T-TAP CONNECTORS SUPPLIED ATTACH ONE TO A POSITIVE SOURCE AND ONE TO A GROUNDED SOURCE.
21. REINSTALL BOTH HEADLIGHT ASSEMBLIES.
22. SET FAIRING BACK INTO THE POSITION WERE YOU UNPLUGGED THE LIGHTS AND PLUG EVERYTHING BACK INTO THE CORRECT SOCKETS. ALSO PLUG THE NEW LED LIGHTS INTO THE T-TAP CONNECTORS AT THIS TIME.
23. CHECK THE FUNCTION OF ALL LIGHTS AT THIS TIME TO MAKE SURE EVERYTHING IS CONNECTED AND WORKING PROPERLY.
24. REVERSE THE STEPS FROM STEP 11 AND UP AND REASSEMBLE EVERYTHING TO COMPLETE THE INSTALLATION.

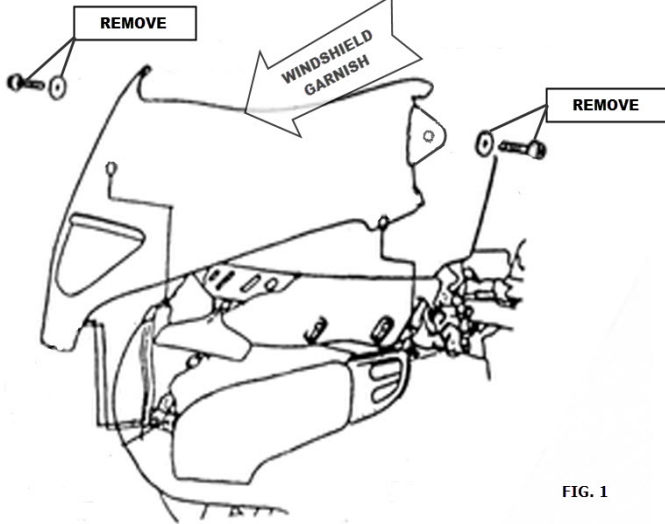

FIG. 1

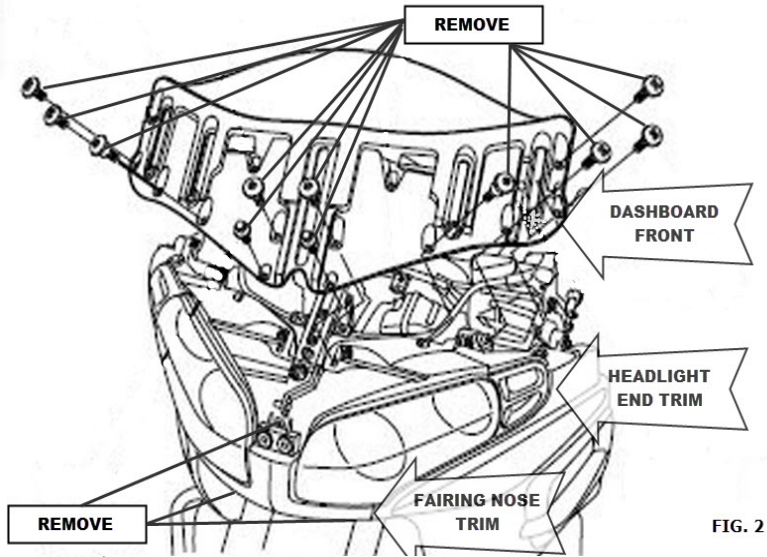

FIG. 2

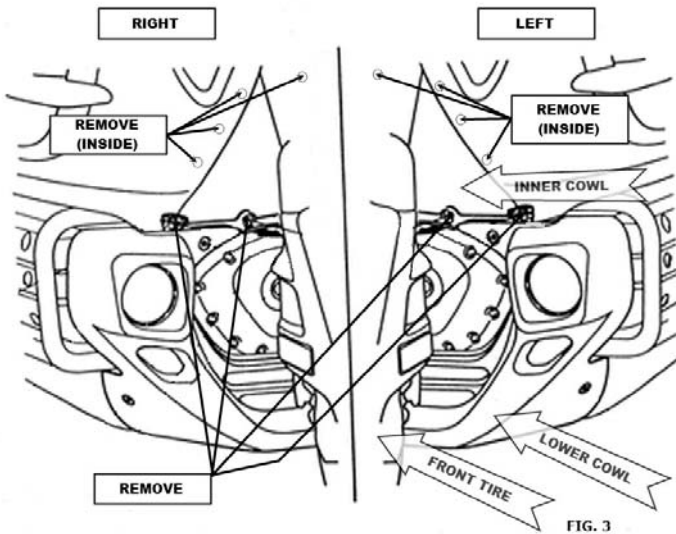

FIG. 3

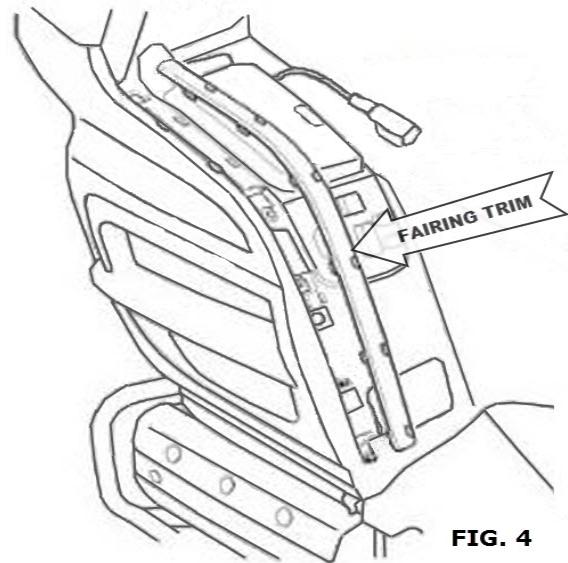

FIG. 4

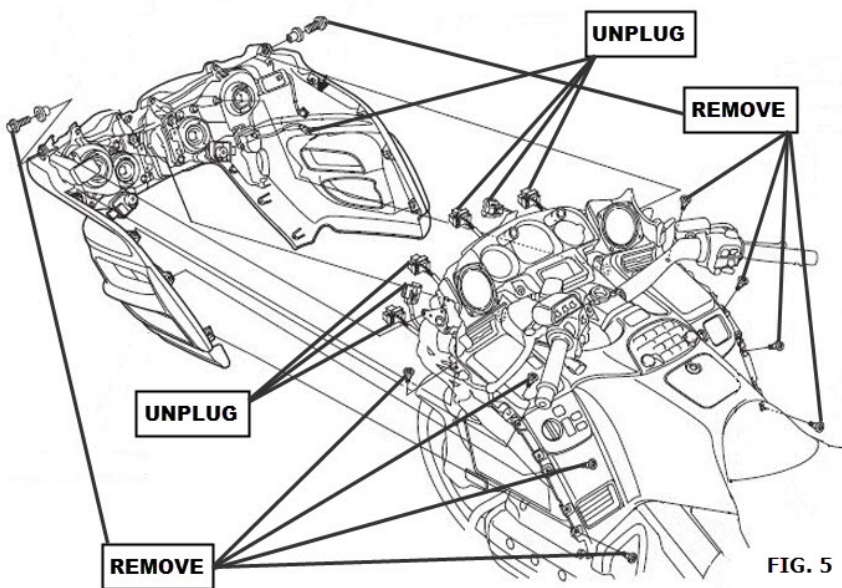

FIG. 5

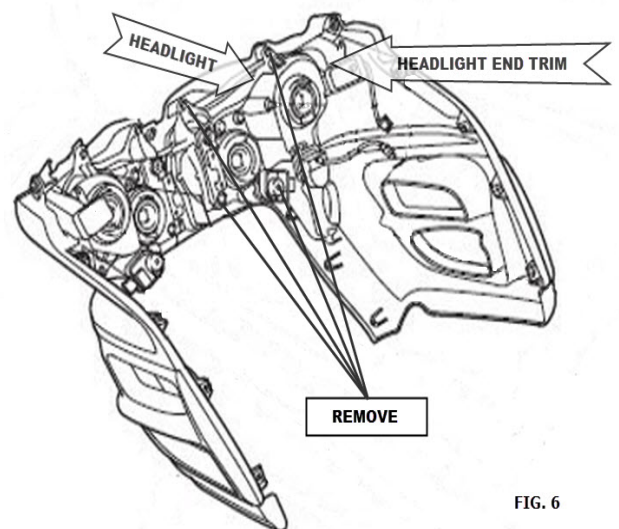

FIG. 6